

## Sectional Reports

### Refractory Materials Section

#### A Method for Thermal Cycling Refractories and an Appraisal of its Effect by a Non-Destructive Technique

T. J. COPPACK  
(Morgan Refractories Ltd)

Read at the Edinburgh meeting of the Refractories Section September 10, 1980.

#### 1. INTRODUCTION

Refractory manufacturers today have to consider many aspects of refractory properties, such as resistance to abrasion, corrosion by molten glass, metals or slags and also behaviour under thermal stress and cycling. It is therefore necessary that the tests designed to evaluate these properties should be capable of comparing them consistently and that the results derived should bear a relationship to their service performance.

Many of the tests used by refractory manufacturers and users are to one of the agreed standards whether it be the A.S.T.M., P.R.E. or British Standard. One test which does present difficulties, particularly when comparing test results, is that of thermal shock. Existing tests can distinguish between excellent and bad but it is difficult to assess the difference between "very good" and "excellent", particularly when resistance is quoted as +20 or +30 cycles.

#### 2. STANDARD THERMAL SHOCK METHODS

The presently available standards for thermal shock testing are as follows.

##### 2.1 Panel test—A.S.T.M. C38

This test<sup>1</sup> is designed to determine the resistance of a refractory brick to the separate and combined effects of structural and thermal spalling. Briefly the test consists of a 24 h preheating stage, after which the panel is cooled and its appearance noted. For spalling the panels are brought to test temperature and then alternated between the furnace and a cooling fan with a water spray. This is carried out for the desired number of cycles after which the bricks are cleaned and reweighed. Any weight loss is noted and this, together with a visual assessment of the panel, are the criteria for comparing thermal shock resistance.

##### 2.2 Cylinder test—water quenching P.R.E./R5 Part 1

Because of its severity, this test<sup>2</sup> cannot be used for all types of refractories. The test is carried out on cored cylinders 50mm diameter and 50mm high. The pieces are

dried at 110°C and then transferred directly into an electric furnace at 950°C, the temperature being brought back to 950°C and held for 15 min. The pieces are then removed into running water at 10–20°C and left for 3 min before returning to the oven for 30 min, then back into the furnace at 950°C. This is repeated until failure, the number of quenches to failure being a measure of thermal shock resistance.

##### 2.3 Prism test—Air quenching—P.R.E./R5 Part 2

This is suitable<sup>2</sup> for the grades which cannot be tested by the previous method. In this case the test-piece size is 114×64×64mm and again the testing temperature is 950°C. Once the temperature is attained, the pieces are soaked for 45 min before removing onto a steel plate and blown by compressed air for 5 min. After quenching, the pieces are tested at a bending stress of 0.3 N.mm<sup>2</sup>. The pieces are then returned to the furnace. This is repeated until failure or, if failure does not occur, the test is discontinued after 30 cycles.

##### 2.4 Small prism test—B.S. 1902, Part 1A

The test-piece size<sup>3</sup> is 3×2×2 in. The pieces are placed in a cold furnace, brought at uniform rate to test temperature, generally 1000°C or 1200°C. The pieces are held at temperature for 30 min before cycling in and out at 10min intervals. Towards the end of each cooling cycle the pieces are examined for cracks or loss of corners. The pieces are then twisted or stressed by means of a rig, the test being concluded when the piece pulls apart. The number of cycles to failure is then the measure of thermal shock resistance.

##### 2.5 Monolithic materials—B.S. 1902, Part 1C

Pieces are prepared by casting or ramming<sup>4</sup> the size being 230×114×76mm. Pieces are prefired by placing in the door of a kiln surrounded by high temperature insulating material. The prefiring temperature is the appropriate service temperature, to which

the kiln is raised in not less than 4 h and held 4 h before cooling.

For shocking, the furnace is brought to temperature with dummy test pieces in the door. Once at temperature the dummy bricks are replaced by the prefired samples. The prefired end is placed into the furnace and the cold end is held in a metal jig. After 20 min the sample is plunged into running water to a depth of 5 cm for 1 min and then allowed to steam for 18 min before returning for further heating.

The test is finished when 10% of the total weight of the brick has spalled away or 20 quenches carried out.

#### 2.6 Limitations of existing methods

Experience has shown that existing test methods are either expensive, both in initial outlay and operational costs, or are limited in their ability to distinguish between different good grades of materials where no obvious physical damage is produced. It is also true to say that the criteria measured in several of the afore mentioned tests is the failure point and not the progressive degree of damage.

It is a measure of the importance attached to the property of thermal shock resistance and the difficulty in measuring it meaningfully that has led to further test methods being explored.

#### 3. RIBBON THERMAL SHOCK TEST

It is not possible to describe all the alternative test methods but one method which has been found to be particularly helpful as a development aid at Neston is based on the Ribbon Test introduced by Taylor Refractories (now Didier Taylor Refractories Co.) and in use by SEMLER & HAWISHER<sup>5</sup> at Ohio State University.

##### 3.1 Historical

The origin of the test goes back as far as the mid to late 1930s, when Taylor Refractories developed a selection test for fireclay baffle plates. The equipment was a single 18 in ring burner in a metal drum, with the test pieces inclined at an angle of 45–60° to the plane of the burner. The test was used to determine a pass/fail rating for each sample after exposure to a series

of unspecified flame on/flame off cycles. It was not until 1947 that the test was re-introduced for cordierite kiln slabs and glass refractory feeder parts. The sample size was 12 in long x 3 in wide x 1 in thick. The evaluation of the shock damage was monitored by modulus of rupture determination.

Early in the 1960s the test equipment was changed to utilize a 5 ft long segmented line burner, which is the basis of the test today. The flame was now directed across the middle of the samples instead of at an angle as previously carried out, the sample size being 9 in long and varying between 4½ in to 1½ in wide by 2½ in to 1 in thick. The height between the burner and the sample face was 4-5 in. The equipment was automated to control the shock cycles, each consisting of 15 min heating to 980°C with flame on and 15 min cooling to 200°C with flame off and air on. The samples received up to 36 shock exposures.

The loss in strength was obtained from the modulus of rupture test. Normally twelve samples were used of any one material, six were tested before shocking and six after. A material with good thermal shock resistance shows a low percentage strength reduction whereas conversely a high reduction in strength denotes poor thermal shock resistance.

Semler's work at Ohio State University has shown that it is not necessary to exceed 10 cycles and even 5 cycles may be sufficient to evaluate thermal shock resistance.

### 3.2 Test equipment (Fig. 1)

The equipment described here is similar to that of Taylor Refractories<sup>8</sup> and Semler. A 5 ft long Maxon segmented burner is held in a metal frame, the test samples being arranged horizontally across the burner at a fixed distance of 5 in from the burner. The rig is fully automated, the start up procedure being by pilot light with the necessary flame failure devices and the cycle length being controlled by time switches. The equipment will accommodate ten brick samples, five each side of the thermocouple block.

### 3.3 Test procedure

Test pieces (230 x 114 x 65 or 38mm) are gap set on the rig, the gap being 25-30 mm. The brick at the centre of the rig, backing the thermocouple, is a Grade 28 insulating brick. The flame is pre-adjusted to touch the underface of the pieces on test. The present setting gives a temperature rise to 1000-1040°C in 15 min, as registered on the thermocouple backed by the insulation brick. The samples are examined non-destructively after 1, 2, 5 and 10 cycles. After 10 cycles, the modulus of rupture is also measured and the percentage retained strengths from both methods compared.

## 4. MEASUREMENT OF THERMAL SHOCK DAMAGE

### 4.1 Physical parameters

There are a number of criteria which can be used for assessing the thermal shock

damage which can use a diversity of different characteristics or combinations thereof.

The most common criteria for assessing thermal shock damage are:

1. visual examination,
2. weight loss,
3. modulus of rupture,
4. modulus of elasticity, (a) by sonic resonance<sup>7</sup>, (b) calculated from ultrasonic velocity<sup>8</sup>, (c) by transient vibration.<sup>9</sup>

The main criterion which we considered in conjunction with the ribbon test was that of modulus of elasticity by transient vibration method.

### 4.2 Selected equipment for E modulus determination (Fig. 2)

The apparatus which was chosen for this work was simple to use and a rapid assessment of a large number of samples could be made easily, with less dependence on the operator. The instrument was originally designed to monitor the "strength" of grinding wheels. Basically the apparatus measures Young's modulus of elasticity (after calculation) by analysing the natural period of the transient vibration which results from a mechanical disturbance of the object under test.

The apparatus uses a piezo-electric probe which is held against the test object; the object is then lightly struck by the

operator, thus setting up the required transient vibration. This signal is amplified in the probe before being fed to the instrument input. The instrument filters out the initial waveform, which is of complex (harmonics) nature, before measuring the duration of eight vibration cycles. The time duration is displayed digitally on the instrument panel and is known as the 'R' reading.

The relevant E-modulus and density can then be calculated from this 'R' value, the weight and dimensions of the sample. (In practice the E modulus equations are complex and a pre-set programme is used in a programmable calculator).

### 4.3 Test method

The test sample may be set on a foam mat or supported by rubber strips positioned at the nodal planes, i.e. 0.22L. The piezo-electric detector and striking position are such that the desired resonance can be measured in any one of three modes, flexural, longitudinal or torsional. The object may be struck in an elastic manner with a plastic hammer or by dropping the plastic handle of a small screw driver onto the sample. This is sufficient for flexural and torsional modes but for longitudinal resonance the sample requires striking with a metal object. The changes in

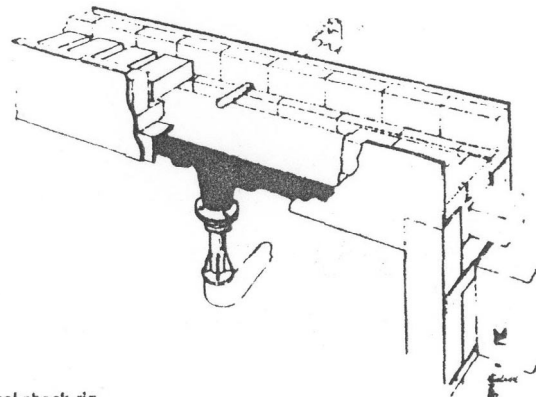

FIGURE 1—Thermal shock rig.

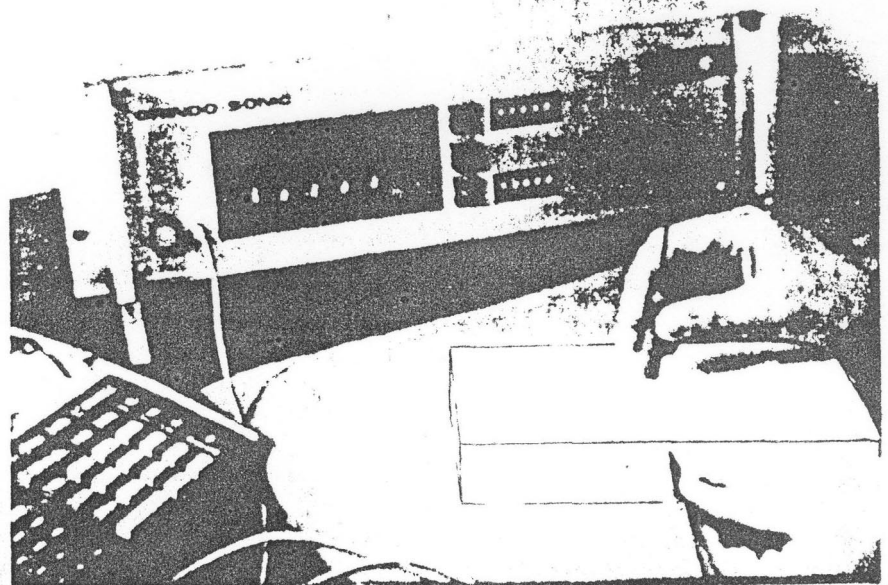

FIGURE 2—Sonic testing.

E-modulus of the test samples are monitored by using the arrangement to obtain the flexural resonance.

## 5. COMPARATIVE DAMAGE ON THERMAL CYCLING

### 5.1 Typical fired refractories

Fig. 3 shows some typical curves obtained on several commercially available refractories from different suppliers. The results are plotted as per cent retained elastic modulus against number of cycles to 1000°C.

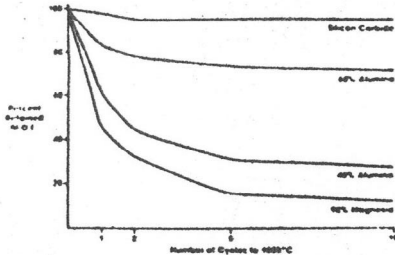

FIGURE 3—Comparative thermal shock damage to refractories.

The materials chosen included a silicon carbide containing material, a 60%  $Al_2O_3$ , a dense 45%  $Al_2O_3$  and a 98% magnesite. This selection was made to include products with very good, medium and poor thermal shock resistance. The sample size chosen for this series of tests was 230 x 114 x 38mm. The results obtained demonstrate what was to be expected, namely the silicon carbide showed highest retained strength whilst magnesite was poorest. It should be mentioned that these materials by the BS 1902 prism test are quoted as +30 and +20 cycles at 1000°C.

In this particular series of tests the samples were allowed to cool to room temperature by removing from the rig after 1, 2, 5 and 10 cycles to permit sample evaluation, which results in slightly increased thermal shock damage. Examination after 2, 5 and 10 or only 5 and 10 cycles will produce slightly slower curves, although the retained strength after 10 cycles is only marginally affected.

It is therefore important to note that if several materials are being compared, they should all be examined after the same cycling procedure and, even more important, they should all be of the same thickness.

Generally, materials which have poor resistance to thermal shock are dramatically affected by sample thickness. A dense firebrick has measureable resistance on a 38mm thick slab but at 65mm the material fails on the first cycle; however, materials which do have poor resistance can still be compared by using a solid pavement arrangement on the rig rather than the gap setting. In this case the degree of thermal shock is reduced.

### 5.2 Relationship of M.O.E. to M.O.R.

Table 1 shows the extremely good agreement obtained between percentage retained M.O.E. and percentage retained M.O.R. after 10 cycles on 63mm thick

Table 1—Relationship of M.O.E. to M.O.R.

Sample Thickness 63mm		
	% Retained M.O.E.	% Retained M.O.R.
45% Alumina	26.4	29.5
60% Alumina	49.4	49.4
63% Alumina	37.1	39.5
68% Alumina	82.3	78.3
72% Alumina	77.2	78.4
90% Alumina	57.6	52.2
Magn./Chrome	44.0	41.3

Percent retained after 10 cycles to 1000°C.

Table 2—Effect of Sample Thickness on Degree of Thermal Shock Damage

	38mm Thick		63mm Thick	
	% Retained M.O.E.	% Retained M.O.R.	% Retained M.O.E.	% Retained M.O.R.
60% Alumina	70.7	60.6	49.4	49.4
90% Alumina	62.2	52.0	57.5	52.2
63% Silicon Carbide	97.4	95.2	94.6	96.1
98% Magnesite	27.6	33.2		

Percent retained after 10 cycles to 1000°C.

samples. Table 2 shows that the agreement between the retained moduli percentages was reduced for thinner test pieces made from alumina-based materials, the retained strength of which fell appreciably with increasing thickness. Thickness had little effect on silicon carbide but the magnesite sample lost all its strength at the greater thickness (not shown). The reasons for this are not yet fully known and further investigative work is in progress. Materials of 60%/70% alumina and below are significantly affected by sample thickness—the 60% alumina showing a marked drop in percent retained strength with increasing thickness, as in the case of the magnesite which has no retained strength after 10 cycles for the particular material measured.

### 5.3 Product variations

Effects of changes in raw materials, batch grading and firing procedures on the thermal shock behaviour of a product can easily be monitored.

The effect of grading changes of a 66%  $Al_2O_3$  material is shown in Fig. 4. The lower curve was the standard material to

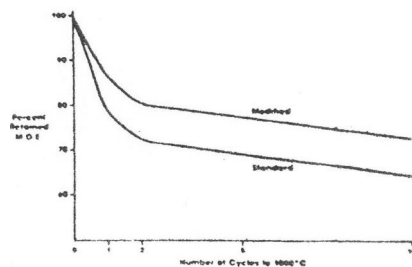

FIGURE 4—Effect of grading changes on a 66% alumina material.

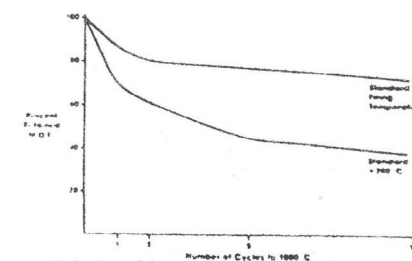

FIGURE 5—Effect of increased firing temperature on a 66% alumina material.

which the modification was made. The percent fines were maintained and the grog distribution rearranged, the effect being an improvement in shock resistance of 12% over the standard material.

Fig. 5 clearly shows that of increasing the standard firing temperature for this particular material by 200°C almost halved the percentage retained M.O.E.

### 5.4 Typical castables

Generally castable materials are regarded as having good thermal shock resistance but extremely poor strength at temperatures in the range 800–1200°C. Fig. 6 shows that in three cement-bonded castables there were very steep reductions in M.O.E. up to 600–700°C followed by a slight levelling and then rises in modulus above 1200–1300°C.

Fig. 7 shows the effect of thermal cycling on differently heat treated 80% alumina castable. The temperatures chosen were 110°, 250°, 600°, 1000°, 1100° and 1400°C. The indications so far are that preheating between 110° and 1100°C did not affect the final M.O.E. after 10 cycles. For the material examined this was 11.5 to 13.5 kN/mm<sup>2</sup> (GPa).

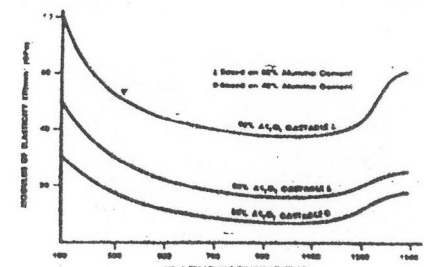

FIGURE 6—Castables: effect of heat treatment on M.O.R.

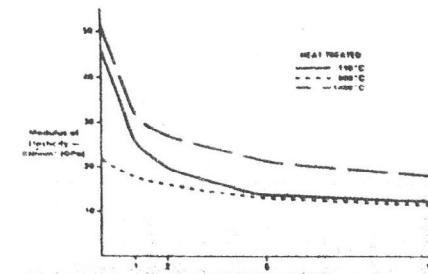

FIGURE 7—Thermal shock damage on an 80% alumina castable.

Prefiring to 1400°C apparently gave an improvement in resistance to shock, but the effect of prefiring to the maximum service temperature throughout or on one face only for a particular castable has to be investigated.

#### 6. CONCLUSIONS

The use of the ribbon test method in conjunction with measurement of M.O.E. by transient vibration has proved of significant assistance in the comparison of various refractory grades for thermal shock resistance and is now proving a

useful tool in the development of new products. It is hoped that, once the parameters of the test are more fully understood and standardised, it will be only necessary to measure elastic modulus before and after 10 cycles or perhaps even 5 cycles will be sufficient.

#### ACKNOWLEDGMENTS

The author would like to thank the directors of Morgan Refractories Ltd. for permission to publish the paper and acknowledges the assistance of his colleagues during its preparation.

#### REFERENCES

1. 1978 Annual Book of ASTM Standards Part 17.
2. PRE Refractory Materials Recommendations 1978.
3. British Standard 1902: Part 1A 1967, Sampling & Physical Tests Appendix B.
4. British Standard 1902: Part 1C 1967, Mouldable & Castable Refractories Method 11.
5. SEMLER, C. E. & HAWISHER, T. H. *Am. Ceram. Soc. Bull.* 69 (7), 732, 1990.
6. Taylor Refractories. Customer Information Bulletin 76-7.
7. DAVIS, W. R. *Trans. J. Brit. Ceram. Soc.*, Vol. 67, 11, 515-541, November 1968.
8. James Electronics Inc.—Ultrasonic Testing of Ceramics and Refractories.
9. Papers from Grindosonic. (J. W. Lemmens—Elektronika N.V., Belgium).